

51V 6,500W PowerFit Alternator

SmartPower Series

CAT # LALTC51V6K-6R

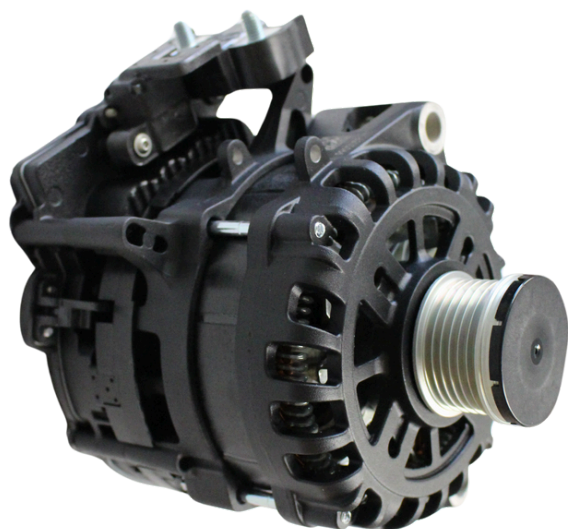

Power Output

Idle: 2,000W at 650 RPM

Cruise: 6,500W at 1500 RPM+

DIMENSIONS

Size (L x W x H):

7.9" x 6.1" x 8.0"

(199.9 x 155.9 x 203.4)

Weight:

16.0lbs

(7.2kg)

Meets Mercedes Sprinter Body & Equipment Guidelines (BEG) Requirements 2023

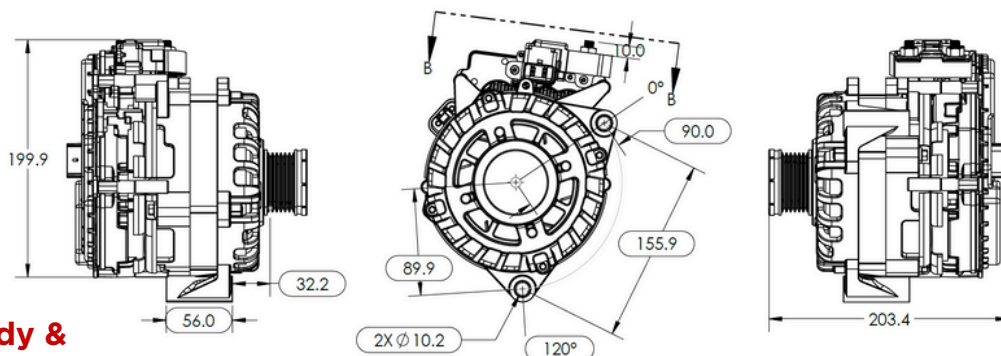

Key Benefits

- ✓ **Charge at Idle: Efficiently charges the battery while vehicle is stationary**
- ✓ **Smooth Running: Uncompromised vehicle drivability and longer accessory belt life**
- ✓ **No Programming Required & Simplified Installation: Lithionics BMS directly controls the alternator**

Reliable Power, Unmatched Safety

The PowerFit is an inverter-based generator that replaces outdated alternators by utilizing MOSFET technology in place of unreliable diodes. The PowerFit features rectangular hair-pin stator winding resulting in greater power output and improved efficiency. Experience reliability, safety, and efficiency with fast-charging capabilities.

SPECIFICATIONS

MECHANICAL

Mercedes Benz N62 Bracket Mount
2x M8x 1.25 (torque nuts to 19Nm \pm 2.5Nm)
Power Terminals
1/0 AWG 5/16" (Quick Cable 5955E)
Recommended Ring Terminal
Dual Cooling Fans
50mm O.D., 6-groove, freewheeling pulley
Housing Material: Magnesium

ACCESSORY LIST

Bracket: N62 Included with Mercedes Volta
System Controller: LSCVoA

ELECTRICAL

Regulation: Internal, requires RV-C CANbus
1/0 AWG Recommended Wire Gauge
Hair-pin rectangular Stator Winding
Up to 85% Efficiency
-30 to 105C
40.0 to 57.6V
RV-C CANbus Protocol Data Communication
8-pin, Molex MX64 Series Low Voltage Connector
Low Voltage Connector Parts:
Housing: Molex 0314049110 or 0314049100
Contacts: TW 2035170-2 or 2035170-1

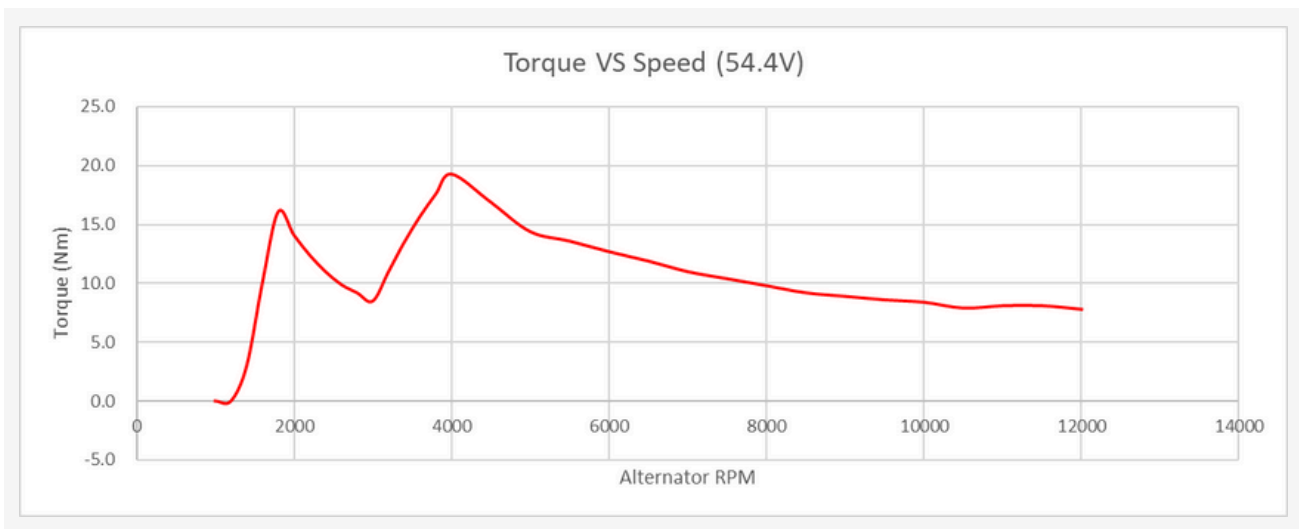

Powering Innovation.

Discover the right lithium replacement system for you. Reach out to Lithionics' expert support team to find your perfect power solution.

DS-024