

PART NUMBER:  
75-H1FCR Ampseal 8 Harness Kit

EXTERNAL  
ACCESSORIES

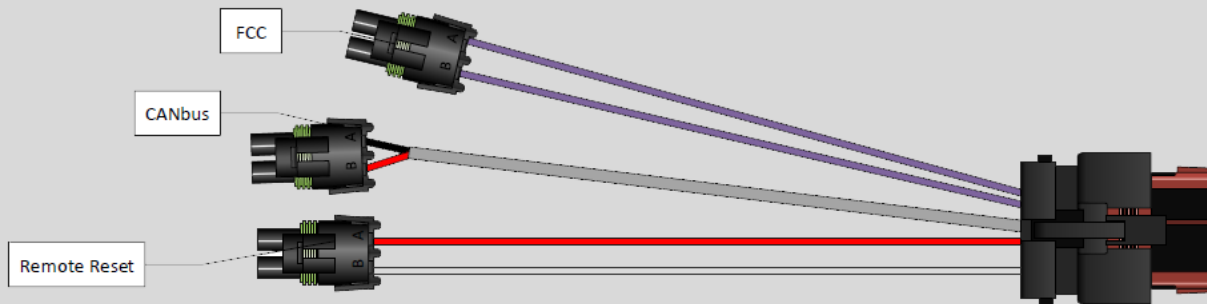

Feature	Description
<b>FCC</b>	Alternator Field Control Circuit
<b>Remote Reset Switch</b>	Remote Momentary Power Switch
<b>CANBus</b>	Limited CANBus RV-C Telemetry

## ABOUT AMPSEAL 8

The mating Ampseal 8 connector kit is designed for use with the Standard series NeverDie® Battery Management System (BMS). The 8 pin Ampseal connector is located on the side of external BMS models (for internal BMS models, this is located on the lid on most batteries), and is used to access the BMS's ported features. This allows implementation of the combination of BMS functions listed above. Mating cable extensions are optional and available separately per the part numbers listed below.



Optional Mating Extensions:		
Part Number	Model	Description
<b>75-149-180</b>	FCC Extension	Dual Weatherpack Connector to Bare Wires, 15ft Length
<b>75-122-180</b>	Remote Reset Extension	Dual Weatherpack Connector to Remote Momentary Reset Switch, 15ft Length

*Note: Contact factory regarding mating connections for CANBus feature.*