

Proprietary and Confidential

This document is the property of Elco Motor Yachts and contains proprietary and confidential information. This document is loaned on the express condition that the information contained therein shall not be disclosed to others without the express consent of Elco Motor Yachts.

Revisions

Rev	Description	Date	Approved
02	New Fuse/Fuseholder	2/16/22	MP
03	Revised Wire Lengths.	6/10/22	MP

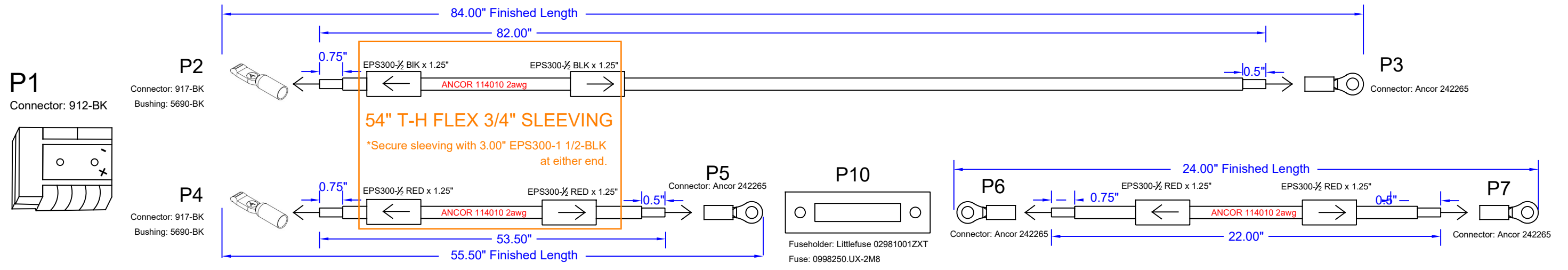

Install P5 and P6 to either sides of fuseholder post assembly.

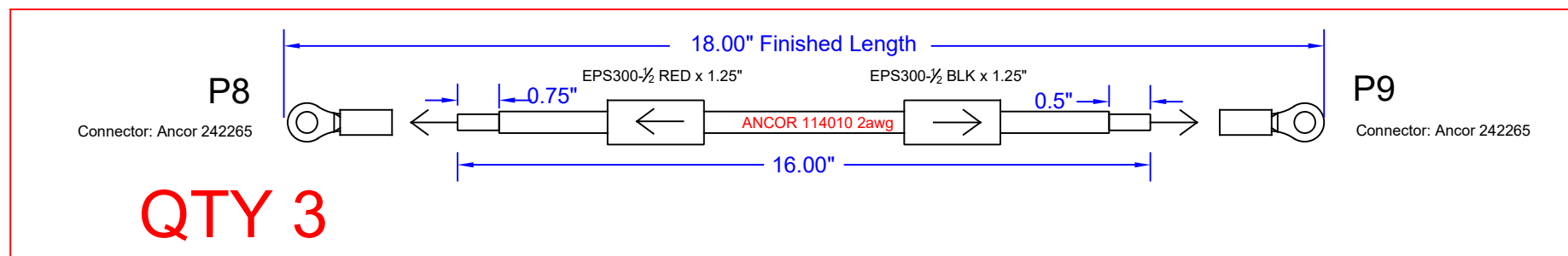

	TITLE		
	Elco EP14-20 Battery Connection Kit		
Drawn	Matt Potter	PART NO.	EP14-20BCKWH01
Date	11/16/2021	DWG NO.	REV NO. 03