



ELECTRIC OUTBOARD

operator's manual





Thank you for purchasing an Elco Electric Outboard Motor.
Your trust in our company and products is greatly appreciated.

Elco electric outboard motors are powerful, economic, safe and manufactured in the USA with advanced technology. Please read this manual carefully before operating your outboard motor. A thorough understanding of the manual will help you to safely operate the product and perform the required maintenance and care. By following the information contained within this manual, your outboard motor will operate for many years.

Elco seeks continuous improvement in product quality. Therefore, while this manual contains the most current product information available at the time of printing, there may be minor discrepancies between your motor and this manual. If there is any question concerning the manual, please consult your local dealer or Elco directly.

Data, illustrations, or explanations in this Operators Manual do not constitute the basis for any legal claim against our company. Please read our limited warranty, which is contained in this manual.

Elco Motor Yachts, LLC

Contents

Main Components	1	Tilting Up and Down (Warnings)	13
Outboard Motor Identification Numbers	2	Tilting Up and Down	14
Propeller Selection	3	Cruising in Shallow Water/Salt Water	15
Installation and Operation	4	Removing/Installing the Propeller	16
Mounting Height Recommendations	5	Checking the Propeller/Changing the Gear Oil	17
Clamping the Outboard Motor	6	Changing the Gear Oil	17-18
Remote Control Mount Pre-Operation Checks	7	Maintenance Table	19-20
Starting the Outboard (Tiller Model)	8	Transporting and Storing	21
Tiller Grip Installation Changing Direction (Tiller Model)	9	Emergency Situations	22
Stopping the Outboard (Tiller Model)	10	Over Current Protection	23
Starting the Outboard (Throttle Control Model)	11	Troubleshooting, Faults and Warnings	24-27
Changing Direction/ Stopping the Outboard (Throttle Control Model)	12	Limited Warranty	27

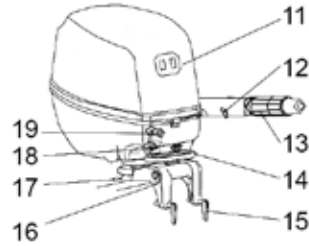
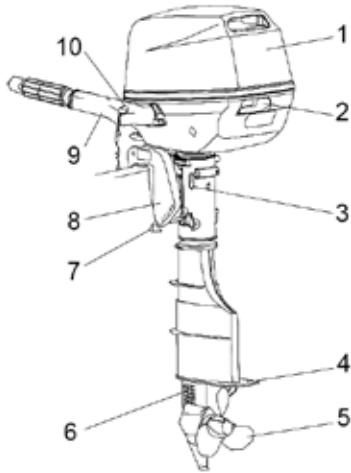

Throttle control - Not Included
Top Mount, Side Mount, Dual Top Mount

- 1. Top cover
- 2. Top cover lock handle
- 3. Steering friction screw
- 4. Anti-cavitation plate
- 5. Propeller
- 6. Cooling water inlet
- 7. Trim rod

- 8. Clamp bracket
- 9. Tiller handle
- 10. Stop button, lanyard switch
- 11. Control switches
- 12. Throttle friction adjuster
- 13. Throttle grip (tiller)
- 14. Carry handle

- 15. Clamp screw
- 16. Rope attachment
- 17. Tilt support bar
- 18. Throttle control cable
- 19. Power cable connector

Outboard Motor Identification Numbers

The outboard serial number is marked on the label. The label can be found on the left bracket assembly or on the upper part of the bracket swivel.

Record your outboard motor serial number in the spaces provided to assist you in ordering spare parts for your Elco dealer to reference.

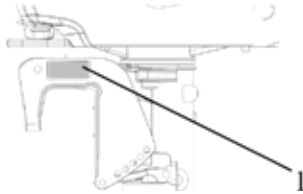

1. Outboard motor serial number location.

Serial number as follows:

SN



Manufacturer's Declaration

The outboard motor complies with the requirements of Directive 2003/44/EC in relation to noise emissions. The following installation and maintenance instructions, if applied, will assist in making sure that the outboard motor will remain in compliance with the noise emissions limits under normal conditions of use.

The performance of your outboard motor will be critically affected by your choice of propeller, as an incorrect choice could adversely affect performance. The outboard motor is fitted with a propeller chosen to perform well over a range of applications, but there may be uses where a propeller with different pitch would be more appropriate. Elco dealers stock a range of propellers and can advise you and install a propeller on your outboard that is best suited to your application.

For a greater boat load and a low motor speed, a smaller-pitch propeller is more suitable. Conversely, a large-pitch propeller is more suitable for a smaller operating load as it enables the maximum motor speed to be maintained.

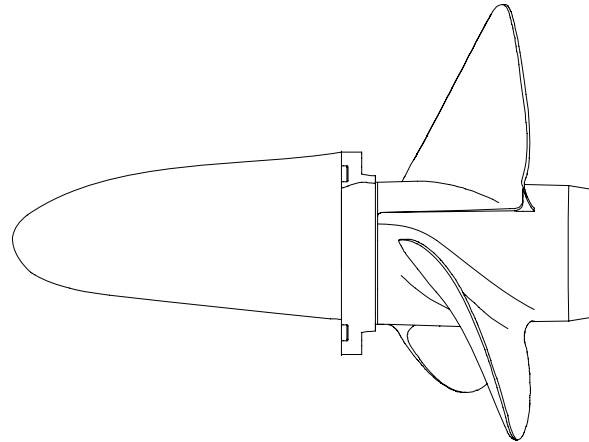

Installation and Operation

Mount the outboard motor on the center line (keel line) of the boat. For boats without a keel or which are asymmetrical, consult your dealer.

During water testing check the buoyancy of the boat when at rest with its maximum load.

WARNING:

- Overpowering a boat could cause severe instability. Do not install an outboard motor with more horsepower than the maximum rating on the capacity plate of the boat. If the boat does not have a capacity plate, consult the boat manufacturer.
- Improper mounting of the outboard motor could result in dangerous conditions and injury. For permanently mounted models, your dealer or other expert experienced in rigging should mount the motor. If you are mounting the motor yourself you should be trained by an experienced person. For portable models, your dealer or other expert experienced in proper outboard motor mounting should show you how to mount your motor.
- The information presented in this section is intended as reference only. Proper mounting depends in part on experience and the specific boat and motor combination.

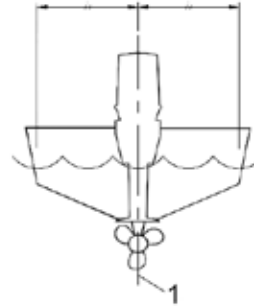

1. Center line (keel line)

The mounting height of the outboard motor greatly affects the running efficiency of your boat. If the mounting height is too high, cavitation tends to occur, thus reducing the propulsion. If the mounting height is too low the water resistance will increase and thereby reduce motor efficiency. Mount the outboard motor so that the anti-cavitation plate is between the bottom of the boat and a level 1 inch below it.

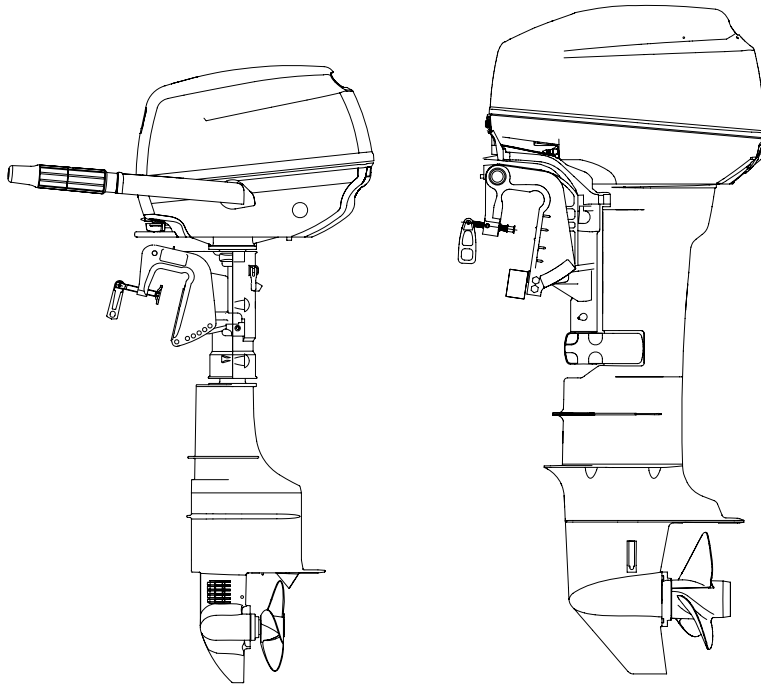

NOTE:

The optimum mounting height of the outboard motor is affected by the boat and motor combination and the desired use. Test runs at different height can help determine the optimum mounting height. For further information, consult your Elco dealer or boat manufacturer.

Clamping the Outboard Motor

1. Tighten the transom clamp screw evenly and securely. Occasionally check the clamp screws for tightness during operation of the outboard motor because they could become loose due to the boat's vibration.

WARNING:

- Loose clamp screws could allow the outboard motor to fall off or move on the transom. This could cause loss of control. Make sure the clamp screws are tightened securely. Occasionally check the screws for tightness during operation.

1. If the outboard restraint cable attachment is equipped on your outboard, an outboard restraint cable or chain should be used. Attach to a secure mounting point on the boat to avoid the outboard being completely lost if it accidentally falls off the transom.



Throttle Control Options



SIDE MOUNT



TOP MOUNT



DUAL - TOP MOUNT

Choose a suitable place on the boat to install the Throttle Control Plank and punch holes in the boat according to the Throttle Control Plank. Fasten the Throttle Control Plank and Throttle Control Box to the boat with a bolt.

Pre-Operation Control Checks

- Make sure the key is in the off position when connecting the batteries.
- Make sure the stop switch is properly connected or the motor will not turn on.
- Check throttle shift and steering for proper operation before starting the outboard.
- The controls should work smoothly, without binding or unusual free play.
- Look for loose or damaged connections.
- Check the operation of the On and Off switch when the outboard motor is in the water.

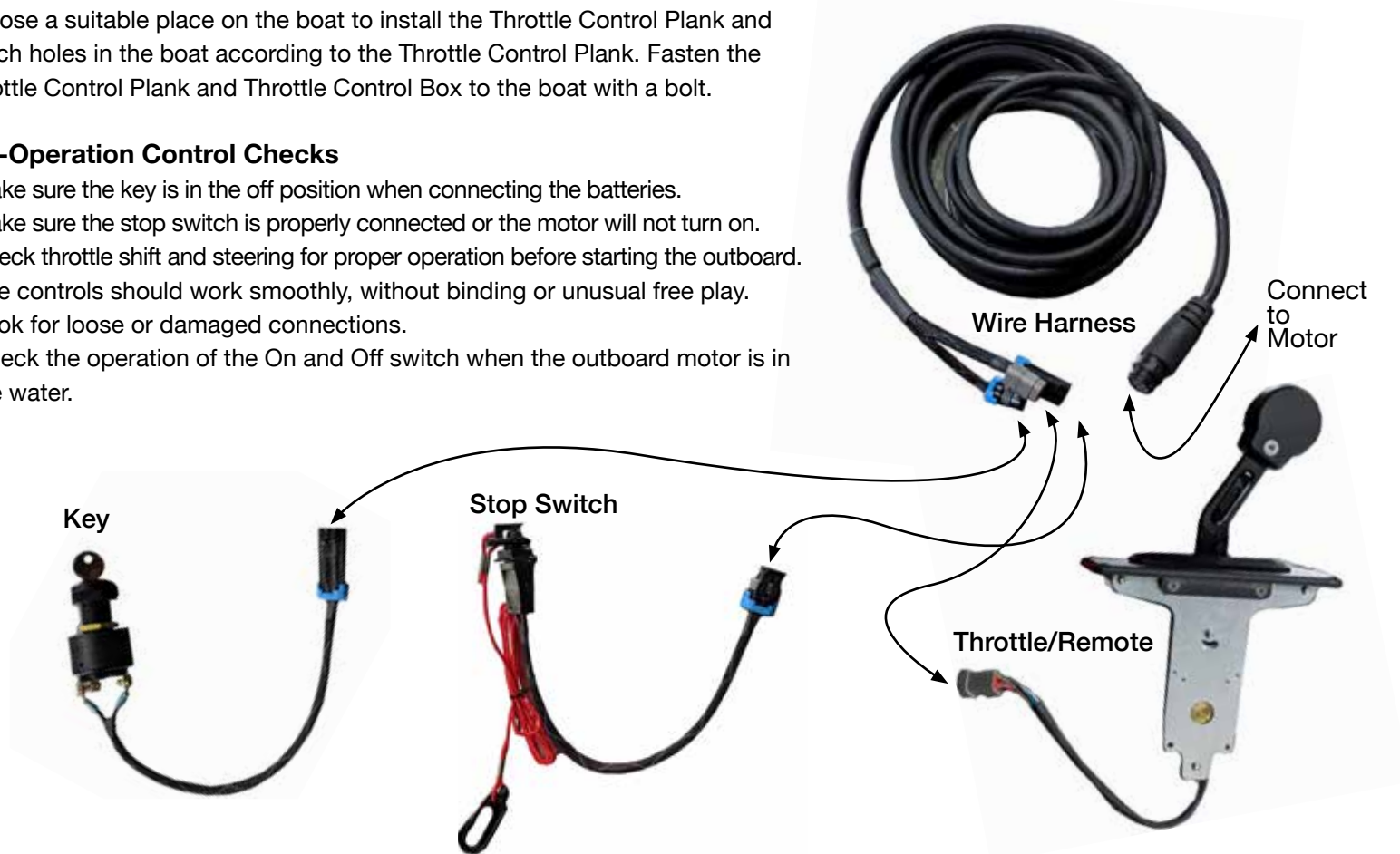

Starting the Outboard (Tiller Model)

CAUTION

- Do not start the outboard out of water. Overheating of the water pump can occur. Serious injury can occur.
- Check the outboard mounting.
- Look for loose or damaged fasteners.
- Check the propeller for damage.

1. Check to see that the On-Off-Battery switch is in the Off position or the motor will not turn on.
2. Attach the outboard Tether Lanyard to a secure place on your clothing, or on your arm or leg.
Then install the lock plate on the other end of the lanyard into the outboard stop switch.
3. Connect the Blue Power Cable to the outboard.
4. Verify the Forward-Reverse switch is in the neutral position or the motor will not turn on.
5. Move the Throttle Grip to the minimum position.
6. Push the On-Off-Battery switch to On.
7. Carefully and slowly move the Throttle Grip to increase the outboard speed.
8. Check for a steady flow of water from the cooling water pilot hole.

WARNING:

- Do not start the outboard unless the Throttle Grip is in the minimum position.
- Do not attach the lanyard to clothing that could tear loose.
- Do not route the lanyard where it could become entangled, preventing it from functioning.

Avoid accidentally pulling the lanyard during normal operation. Loss of engine power means the loss of steering control. Also, without engine power, the boat could slow rapidly. This could cause people and objects in the boat to be thrown forward.

Always attach lanyard to clothing or wrist when operating the outboard.

Tiller Grip Installation / Changing Direction (Tiller Model)

9

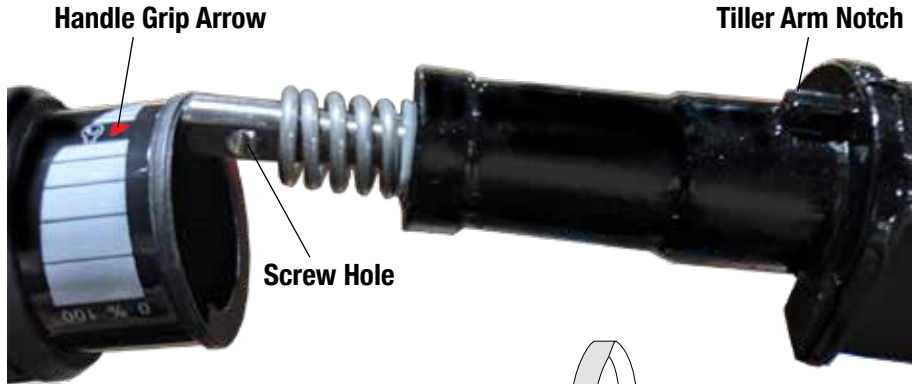

When installing the throttle grip, make sure the screw hole is straight in-line with the red handle grip arrow and the tiller arm notch. When installed properly the grip should turn fully without resistance.



1. Place the throttle grip in the fully closed position.
2. Move the Forward-Reverse switch to the desired direction/position.

NOTE:

The outboard motor can turn 90° in its bracket. The boat can also be backed up by simply turning the outboard motor around 180° with the steering handle facing toward you.

CAUTION:

• You can change direction at any time, even with the Throttle Grip in the full speed position. This can cause a shifting of loads in the boat, but may be necessary if you are moving too quickly towards a dock.

WARNING:

• When operating in reverse, go slowly. Do not open the throttle to more than half speed, otherwise the boat could become unstable, which could result in loss of control and an accident.

Stopping the Outboard (Tiller Model)

PROCEDURE:

1. Push the On-Off-Battery switch to the Off position.

NOTE:

The outboard can also be stopped by pulling the lanyard and removing the lock plate from the Tether stop switch.

In emergency situations, the main Power Cable connector can also be removed to disconnect power from the outboard.

Throttle Friction Adjuster

The throttle friction adjuster is on the tiller handle, and provides adjustable resistance to movement of the throttle grip, and can be set according to operator preference.

To increase resistance, turn the adjuster clockwise. To decrease resistance, turn the adjuster counter-clockwise. When constant speed is desired, tighten the adjuster to maintain the desired throttle setting.

WARNING:

Do not over-tighten the friction adjuster. If there is too much resistance, it could be difficult to move the throttle lever or grip, which could result in an accident.



1. Check to see that the Key switch is in the Off position.
2. Attach the motor stop switch lanyard to a secure place on your clothing, or your arm or leg.
Then install the lock plate on the other end of the lanyard into the outboard stop switch.
3. Connect the Blue Power Cable to the outboard.
4. Verify the Throttle Lever is in the neutral position.
5. Turn the Key Switch to On by rotating clockwise.
6. Depress the Handle switch on the Throttle Lever and rotate the Throttle Lever forward (for forward direction) or Reverse (for the reverse direction).
7. Carefully and slowly move the Throttle Lever to increase or decrease the outboard speed.
8. Check for steady flow of water from the cooling water pilot hole.

WARNING:

- Before changing direction, make sure there are no swimmers or obstacles in the water near you.
- Shifting from forward to reverse or vice versa is possible at any time, but care must be taken to prevent people and equipment from shifting in the boat.

Changing Direction (Throttle Control Model)

1. Place the throttle lever in the upright position for neutral.



TOP MOUNT



SIDE MOUNT

2. Rotate the Throttle Control Lever forward for the forward boat direction, and rotate the Throttle Control Lever backwards for the reverse direction.

Stopping the Outboard (Throttle Control Model)

PROCEDURE:

1. Return the Throttle Lever to the neutral position
2. Turn the Key Switch to the off position

NOTE:

The outboard can also be stopped by pulling the lanyard and removing the lock plate from the Tether Lanyard switch. In emergency situations, the main Power Cable connector can also be removed to disconnect power from the outboard.

If the motor will be stopped for some time or if the boat is docked or stopped in shallow water, the outboard motor should be tilted up to protect the propeller and casing from damage by collision with obstructions, and also to reduce corrosion.

WARNING:

Be sure all people are clear of the outboard motor when tilting up and down. Also be careful not to pinch any body parts between the drive unit and outboard bracket.

Remove the Power Cable if the outboard motor will be tilted for more than a few minutes. Otherwise, an unsafe condition may exist.

NOTE:

- Do not tilt up the outboard by pushing the tiller handle because this could break the handle.
- The outboard motor cannot be tilted when in reverse or when the outboard motor is turned 180 degrees (facing the rear).

Tilting Up

1. Place the On-Off-Battery switch in the Off position and face the outboard motor forward.
If this is a Throttle Control Model, turn the Key switch to off and remove the key.
2. Tighten the steering friction screw by turning it clockwise to prevent the motor from turning freely.
3. Disconnect the Power Cable from the outboard motor.
4. Hold the rear handle and tilt the outboard up fully until the tilt support bar automatically locks.



Tilting Down

1. Slightly tilt the outboard motor up.
2. Slowly tilt the outboard motor down while pulling the tilt support bar lever up.
3. Loosen the steering friction screw by turning it counter clockwise, and adjust the steering friction according to operator preference.

WARNING:

- The outboard motor can be tilted up partially to allow for operation in shallow water.
- The tilt lock mechanism does not work while the shallow water cruising system is being used. Run the boat at the lowest possible speed to avoid the outboard motor being lifted out of the water, resulting in loss of control.
- Return the outboard motor to its normal position as soon as the boat is back in deep water.

CAUTION:

The cooling water inlet on the lower unit should be not above the surface of the water when setting up for and cruising in shallow water. Otherwise severe damage from overheating can result.

Cruising in Salt Water

After operating in salt water, wash out the cooling water passages with fresh water to prevent them from becoming clogged with salt deposits.

Maintenance Procedures

While using the outboard motor, periodic maintenance is necessary for you to ensure its performance of the motor.

WARNING:

- Be sure to turn off the outboard when you perform maintenance unless otherwise specified. This work should always be done by a qualified mechanic or your authorized ELCO dealer.

CAUTION:

If replacement parts are necessary, use only genuine ELCO parts.

Removing/Installing the Propeller

1. Check each of the propeller blades for wear, erosion from cavitation or ventilation, or other damage.
2. Check the propeller shaft for damage.
3. Check the splines/shear pin for wear or damage.
4. Check for fish line tangled around the propeller shaft.
5. Check for the propeller shaft oil seal for damage.

Removing the Propeller

1. Straighten the cotter pin and pull it out using a pair of pliers.
2. Remove the propeller nut, washer, and spacer (if equipped).
3. Remove the propeller and thrust washer.

Installing the Propeller

CAUTION:

- Be sure to install the thrust washer before installing the propeller, otherwise the lower case and propeller boss could be damaged.
 - Be sure to use a new cotter pin and bend the ends over securely. Otherwise the propeller could come off during operation and be lost.
1. Apply a marine grease or corrosion resistant grease to the propeller shaft.
 2. Install the spacer (if equipped), thrust washer, and propeller on the propeller shaft.
 3. Install the spacer (if equipped) and the washer.
 4. Tighten the propeller nut. Align the propeller nut with the propeller shaft hole. Insert a new cotter pin in the hole and bend the cotter pin ends.

WARNING:

- Before inspecting, removing or installing the propeller, always take actions to ensure the outboard does not accidentally start, such as removing the Power Cable connector, placing the On-Off-Battery switch in the Off position, (or remove the Key for the Throttle Control Model) and removing the lanyard from the outboard Tether stop switch, etc. Serious injury can occur if the outboard should start and you are standing too close to the propeller.
- Do not use your hand to hold the propeller when loosening or tightening the propeller nut. Put a wood block between the anti-cavitation plate and the propeller to prevent the propeller from turning.



1. Oil level plug
2. Gear oil drain screw

Changing the Gear Oil

WARNING:

- Be sure the outboard motor is securely fastened to the transom or a stable stand.
 - Never get under the lower unit while the outboard motor is tilted, even when the tilt support lever or knob is locked. Serious injury could occur if the motor falls.
1. Tilt the outboard motor so that the gear oil drain screw is at the lowest point possible.
 2. Place a suitable container under the gear case.
 3. Remove the gear oil drain screw.
 4. Remove the oil level plug to allow the oil to drain completely.

Changing the Gear Oil

CAUTION:

Change the gear oil after the first 10 hours of operation, and then every 100 hours or at 6-month intervals thereafter. Otherwise the gear will wear quickly.

CAUTION:

Inspect the used oil after it has been drained. If the oil is milky, then water is getting into the gear case which can cause gear damage. Consult your ELCO dealer.

5. Use a flexible or pressurized filling device, inject the gear oil into the gear oil drain screw hole. Standard 80-90 gear oil is recommended.
6. When the oil begins to flow out of the oil level plug hole, insert and tighten the oil level plug (If necessary, change the seal spacer).
7. Insert and tighten the gear oil drain screw (If necessary, change the seal spacer).

Checking and Replacing the Anode

Inspect the external anode periodically. Remove scales from the surfaces of the anode. Consult your ELCO dealer for replacement of external anode.

CAUTION:

Do not paint anodes, as this would render them ineffective and can cause more rapid motor corrosion.

Greasing

The Greasing points are shown in diagram A

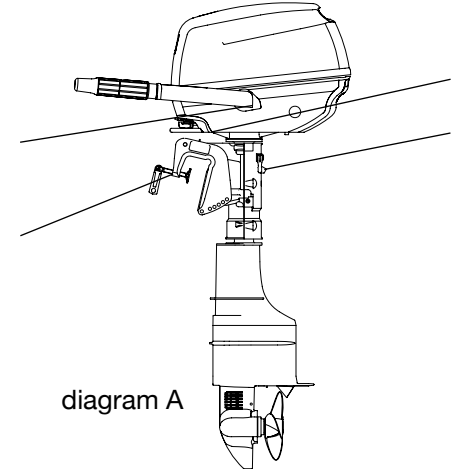

Date	Service Information

Maintenance Table

Frequency of maintenance operations may be adjusted according to the operating conditions, but the following table gives general guidelines.

The “●” symbol indicates the check-ups which you may carry out by yourself.

The “○” symbol indicates work to be carried out by your ELCO dealer.

NOTE: When operating in salt water, turbid or muddy water, then engine should be flushed clean after every use.

Item	Operations	Initial		Every	
		10 hours (1 month)	50 hours (3 months)	100 hours (6 months)	200 hours (1 year)
Anode(s) (external)	Check/replacement		● / ○	● / ○	
Anode(s) (internal)	Check/replacement				○
Cooling water passages	Cleaning		●	●	
Cowling clamp	Check				●
Gear oil	Change	●		●	
Greasing points	Greasing			●	
Propeller and cotter pin	Check/replacement		●	●	
Shift link/shift cable	Check/adjustment				○
Throttle link/throttle cable/ throttle pick-up timing	Check/adjustment				○
Water pump	Check				○

The outboard motor should be trailed and stored in the normal running position. If there is insufficient road clearance in this position, then trailer the outboard motor in the tilt position using a motor support device.

CAUTION:

Do not use the tilt support lever or knob when trailering the boat. The outboard motor could shake loose from the tilt support and fall.

WARNING:

- Never get under the lower unit while it is tilted, even if a motor support bar is used.

CAUTION:

- Place a towel or something similar under the outboard motor to protect it from damage.

Checking the Top Cover

Check the fitting of the top cowling by pushing it with both hands. If it is loose have it repaired by your Elco dealer.

Storing

When storing your ELCO outboard motor for prolonged periods of time (2 months or longer), several important procedures must be performed to prevent damage.

It is advisable to have your outboard motor serviced by an authorized ELCO dealer prior to storage. However, you, the owner, with a minimum of tools, can perform the following procedures.

CAUTION:

- Keep the outboard motor in an upright position when transporting and storing it. If storing or transporting the outboard motor on its side (not upright), put it on a cushion.
- Do not place the outboard motor on its side before the cooling water has drained from it completely.
- Store the outboard motor in a dry, well-ventilated place, not in direct sunlight.



Emergency Situations

Impact Damage

If the outboard motor hits an object in the water, follow the procedure below.

1. Stop the outboard immediately.
2. Inspect the control system and all components for damage.
3. Whether damage is found or not, return to the nearest harbor slowly and carefully.
4. Have an ELCO dealer inspect the outboard motor before operating it again.

Treatment of Submerged Outboard

If the outboard is submerged, immediately take it to an ELCO dealer. Otherwise some corrosion may begin almost immediately.

CAUTION:

Do not attempt to run the outboard motor until it has been completely inspected.

Low Battery Shutdown

You should wait a few minutes for the battery voltage to rise, restart the outboard, and proceed slowly to shore. You can go much farther with a low throttle setting than if you use a full throttle setting.

Over-current Protection

A fuse must be placed at the source of power (batteries) for each circuit or conductor except:

1. If it is physically impractical to place the circuit breaker or fuse at the source of power, it may be placed within seven inches of the source of power for each circuit or conductor, measured along the conductor.
2. If it is physically impractical to place the circuit breaker or fuse at or within seven inches of the source of power, it may be placed within 40 inches of the source of power for each circuit or conductor, measured along the conductor, if the conductor is contained throughout its entire distance between the source of power and the required circuit breaker or fuse in a sheath or enclosure such as a junction box, control box, or enclosed panel.

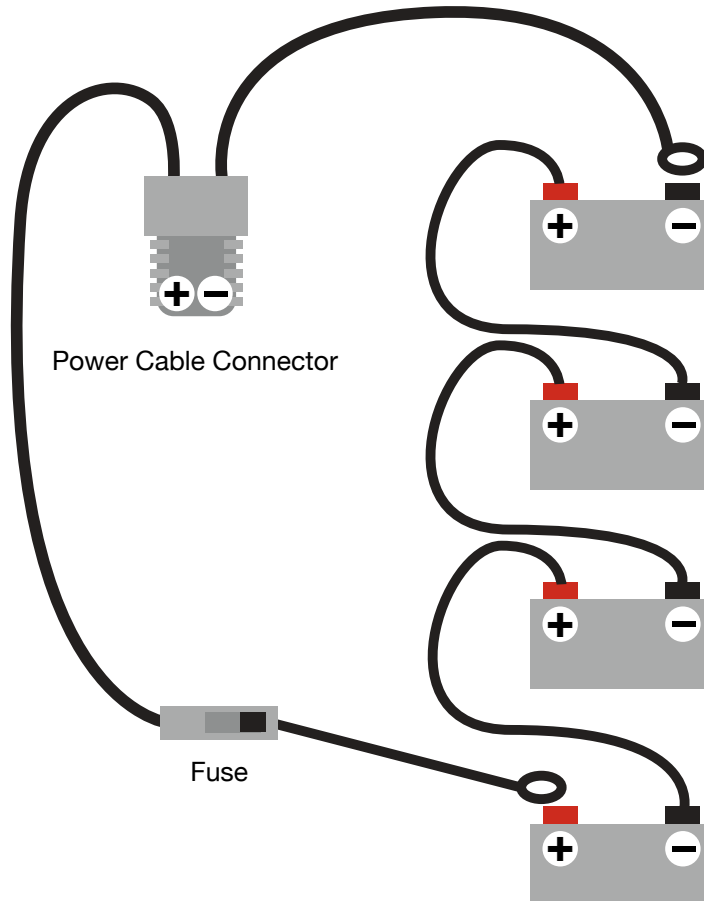

Battery Installation

This diagram is intended for reference only.

Please keep propulsion battery bank separate from house bank.

It is highly recommended that batteries be mounted in rugged, covered boxes designed for this purpose.

Consult an ABYC certified marine electrical professional for system design and circuit protection.

Troubleshooting: Faults & Warnings

Use the table below to determine the type of fault from the number of LED flashes. The LED flashes a preset number of times in repetitive sequence (e.g. 3 flashes – off – 3 flashes – off – and so on). Possible operator action is listed in the right hand column of the table.



LED flashes	Fault	Set Conditions	Operator Action
2	Throttle Control Fault	Throttle Sensor Fault	Disconnect throttle cable and check for damage
3	Hardware over current trip activated	hardware over current circuit activated	Check motor load and wiring. Check motor parameters are correct.
5	PST Fault	Fault detected on PST power tee module.	Check PST condition.
5	Motor open circuit	Unable to establish current in motor.	Check motor condition/wiring.
6	Throttle pressed at power up	Throttle demand is greater than 20% at power up.	Reduce demand
6	Analog input wire-off	Analog input voltage is outside allowable range.	Check analog input wiring
6	Analog output fault(over/under current, failsafe, short circuit driver)	Analog output fault caused by over current (>4A), under current if actual current <50% target (current mode only), failsafe circuit fault, short circuit driver MOSFET.	Check analog output wiring.

LED flashes	Fault	Set Conditions	Operator Action
7	Battery low voltage protection	Battery voltage or capacitor voltage is below a user definable minimum battery level for a user definable time.	Increase battery voltage above user defined level
7	Controller low voltage protection	Battery voltage or capacitor voltage is below the minimum level allowed for the controller.	Increase battery voltage above minimum level
7	Controller high voltage protection with line contactor closed.	Battery voltage or capacitor voltage is below the minimum level allowed for the controller.	Increase battery voltage above minimum level.
7	Battery high voltage protection	Battery voltage or capacitor voltage is above a user definable maximum battery level for a user definable time.	Investigate and reduce battery voltage below user defined maximum level.
7	Motor low voltage protection	Capacitor voltage has entered the motor low voltage cutback region defined in 4612	Reduce battery voltage below start of motor high voltage cutback region
7	Controller high voltage protection with line contractor open.	Battery voltage or capacitor voltage is above the maximum level allowed for the controller with line contactor open.	Isolate controller and investigate high battery voltage
7	BDI warning or cutout	BDI remaining charge is less than warning or cutout levels.	Charge battery.

Troubleshooting: Faults & Warnings

LED flashes	Fault	Set Conditions	Operator Action
7	Battery voltage below critical level for controller.	Battery voltage is below the absolute minimum voltage at which the controller hardware is guaranteed to operate.	Increase battery voltage
7	Precharge failure	Capacitor voltage is less than 5V after pre-charge operation is complete.	Check controller wiring to ensure there are no short circuits between B+ and B-.
8	Controller too hot	Controller has reduced power to motor(s) below maximum specified by user settings due to controller over temperature.	Remove loading to allow controller to cool down.
8	Controller too cold	Controller has reduced power to motor(s) below maximum specified by user settings due to controller under temperature.	Reduce load to motor to allow it to cool down.
8	Motor over temperature	Controller has reduced power to motor(s) below maximum specified by user settings due to motor over temperature	Reduce load to motor to allow it to cool down.
8	Motor too cold	Motor thermistor reports less than -30°C.	Allow motor to warm up. Check motor thermistor.
11	Current control fault	Software is unable to control currents on PMAC motor.	Check motor load and wiring. Check motor parameters are correct

LED flashes	Fault	Set Conditions	Operator Action
13	Current sensor auto-zero fault	Current sensor voltage out of range with no current	Check controller wiring to ensure there are no short circuits between B+ and B-.
13	DSP Parameter error	Motor parameter written to while motor control is operational.	Recycle key switch to allow parameters to be reloaded correctly.

Limited Warranty

The Elco Motor Yachts, LLC ("Elco") Electric Propulsion System ("EPS" or "product") is warranted to the original retail purchaser to be free from defects in material for a period of three years and/or workmanship for a period of two years from the date of purchase, each under normal operating conditions. Provided that the warranty registration card (located in the Owner's Manual or on the website) is completed and returned to Elco within 15 days of purchase, this non-transferable Limited Warranty shall begin on the date the EPS is sold to the original retail purchaser or the date on which the product is first put into service, whichever occurs first.

This Limited Warranty does not cover product damage due to abuse, accidents, modifications, misuse, excessive wear or damage caused by an owner's failure to provide reasonable and necessary installation and care. Purchasing of the unit from anyone other than an Elco authorized Dealer and/or having the product serviced or repaired by anyone other than an Elco authorized repair facility will void this warranty. Pursuant to the terms of this Limited Warranty, during the applicable warranty period, Elco will repair or replace any defect arising from imperfect material or workmanship, without charge, provided that such defective or imperfect part when discovered shall be immediately reported in writing and returned to an Elco authorized repair facility.

Use of the EPS in any manner other than its intended use (i.e., in marine craft only) will void this warranty.

The EPS must be inspected to make sure no damage has occurred during shipping. Any damage must be reported to Elco immediately in writing at the address set forth at the end of this Limited Warranty. In addition, the allegedly defective EPS must be delivered to the nearest Elco authorized repair facility. The aforementioned notification shall state, (1) that the EPS is an Elco product and shall include a copy of the proof of purchase (i.e., the receipt or invoice), (2) that warranty consideration is requested and (3) the name and address of the Elco authorized repair facility holding the allegedly defective product. Elco will promptly consider all such warranty claims.

As stated above, Elco's sole obligation under this Limited Warranty is (at its sole option and discretion) to repair or replace any defective component or product in part or whole. Elco shall be the sole arbiter of such action. In the event that Elco elects to replace the EPS, Elco shall supply such replacement F.O.B. Elco factory or authorized repair facility, as Elco may elect in its sole discretion.

Elco will not accept warranty obligations for repair of products by other than its authorized repair facility or warranty obligation for materials or workmanship employed in making repairs. This Limited Warranty does not cover cost of removal, transportation to and from repair facilities, or re-installation.

Elco products requiring service not covered under the terms of this Limited Warranty may be repaired or replaced by Elco for a fee to be determined by Elco at the time of such repair or replacement.

Be sure to save the receipt or invoice you were given when you bought your EPS. It is your proof of purchase and Elco must see it before Elco will honor this Limited Warranty.

Elco makes no warranty other than that stated above, either express or implied and expressly disclaims same.

ALL INCIDENTAL AND/OR CONSEQUENTIAL DAMAGES ARE EXCLUDED FROM THIS WARRANTY. IMPLIED WARRANTIES ARE LIMITED TO THE LIFE OF THIS WARRANTY. SOME STATES DO NOT ALLOW LIMITATIONS ON HOW LONG AN IMPLIED WARRANTY LASTS OR THE EXCLUSION OR LIMITATION OF INCIDENTAL OR CONSEQUENTIAL DAMAGES, SO THE ABOVE LIMITATIONS OR EXCLUSIONS MAY NOT APPLY TO YOU. THIS WARRANTY GIVES YOU SPECIFIC LEGAL RIGHTS, AND YOU MAY ALSO HAVE OTHER LEGAL RIGHTS WHICH MAY VARY FROM STATE TO STATE.

Elco Motor Yachts, LLC 2016

Save this Operators Manual

You can also download at elcomotoryachts.com

The future of our environment
depends on the choices we make today.

Go Electric



877.411.ELCO (3526) | elcomotoryachts.com

